

Dense permanent magnetic chuck

Usage:

Permanent Magnetic Chuck for fastening thin , small Work piece on Grinding, EDM, especially in liquid.

Features:

- 1) Dense distance between magnetic poles \rightarrow reach $(1+0.5)$ mm and the product can get effective magnetic force.
- 2) Using special sliding mode ,can control the tolerance accurately.
- 3) Easy handle operating.

Magnetic Chuck

Permanent Magnetic chuck

Permanent Magnetic chuck can be used for processing various magnetic conduction workpieces, especially thin and small pieces, in-surface grinder, tool grinder and electric sparks machine tools.



Model	Dimension			Magnetic (N/cm ²)	N.W (kg)
	Length	Width	Height		
XC160x75	50	75	160	120	4.5
XC160x100	160	100	50	120	6.0
XC200x150	150	60	200	120	11.5
XC200x100	200	100	50	120	8.0
XC300x150	300	150	50	120	17.5
XC350x150	350	150	50	120	20.5
XC400x150	400	150	50	120	23.5
XC400x200	400	200	50	120	31.0
XC450x150	450	150	50	120	26.0
XC500x200	500	200	50	120	39.0

Standard permanent magnetic chuck

Features:

- 1 major in the field of grinding ;fasten the work piece on EDM or surface grinder
- 2 widely used and the cheapest permanent magnetic chuck.

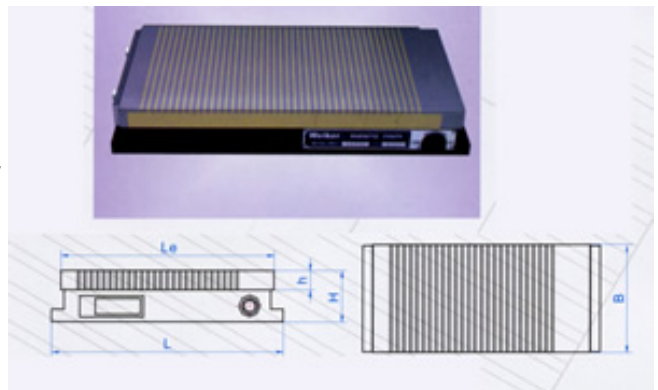

Type	dimension					Weight (kg)
	B	Le	L	H	h	
XMC-1018Q	106	179	192	46	18	6.5
XMC-1325Q	130	250	220	46	18	11
XMC-1530Q	150	300	320	50	20	17
XMC-1535Q	150	350	370	55	20	21
XMC-1540Q	150	400	420	55	20	24
XMC-1545Q	150	450	471	55	20	26
XMC-2040Q	200	400	420	56	20	32
XMC-2050Q	200	500	520	57	20	42
XMC-2063Q	200	630	660	57	20	54
XMC-2540Q	250	400	424	57	20	42
XMC-2563Q	250	630	654	60	20	70
XMC-3240Q	320	400	430	60	20	57

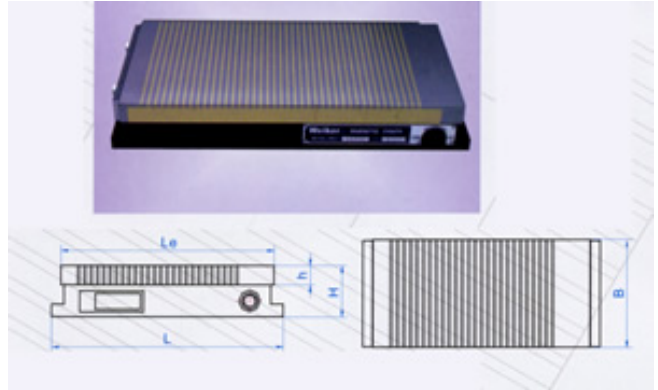

Type	Dimension					Weight
	B	Le	L	H	h	
XMC-1018Q1	106	179	192	46	18	6.5
XMC-1325Q1	130	250	220	46	18	11
XMC-1530Q1	150	300	320	50	20	17
XMC-1535Q1	150	350	370	55	20	21
XMC-1540Q1	150	400	420	55	20	24
XMC-1545Q1	150	450	471	55	20	26
XMC-2040Q1	200	400	420	56	20	32
XMC-2050Q1	200	500	520	57	20	42
XMC-2063Q1	200	600	660	57	20	54

Distance between magnetic poles (P+P1) reach 3mm (1+2)mm

Type	Dimension(mm)					Weight (kg)
	B	Le	L	H	h	
YXC-2540Q	250	400	424	57	57	42
YXC-2563Q	250	630	654	60	60	70
YXC-3240Q	320	400	430	60	60	57

Rotary permanent magnetic chuckUsage:

Suited to angle grinding on the grinding machine.

Features:

- 1)The angle scale on the rotary shaft makes it easy to grind at any angle.
- 2)High intensity ,the chuck and the shaft as a whole
- 3)When Turning magnetic force ON/OFF the flat face 's accuracy of magnetic force surface not changed.

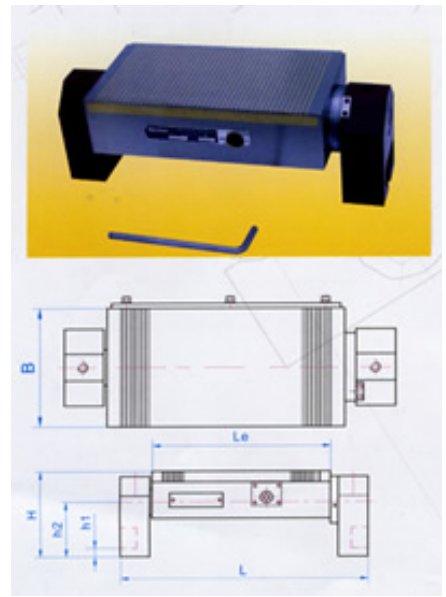

Type	B (mm)	Le (mm)	H (mm)	H2 (mm)	L (mm)	H1 (mm)	Weight (kg)
XMRC1530Q	150	300	146	94	418	15	33
XMRC1535Q	150	350	146	94	468	15	37

Permanent Square type block

Usage:

Used in surveying ,lineation and light process.

Features:

- 1) no damage to the measured goods .accurately tolerance mensuration.
- 2) Above ,both sides, V side ,cross side have suction ,could test the difficult special work piece.
- 3) Simple handle-operated with spiral switch.

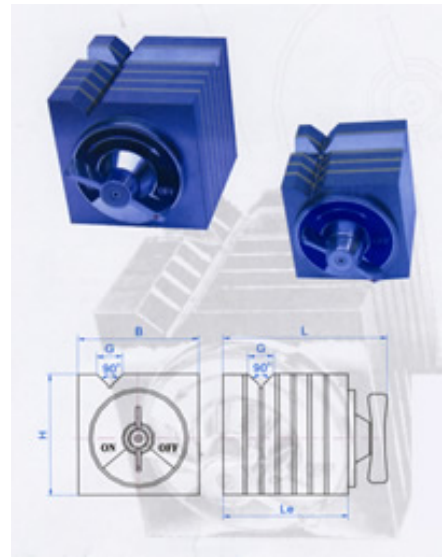

Type	Holding strength	Dimension(mm)					Weight (kg)
		B	Le	L	H	G	
YX-100	500	100	108	146	100	26	7
YX-150	1500	150	154	204	150	32	26